

# ferroli

## RMP<sup>2</sup> HE

AIR-WATER CHILLERS AND HEAT PUMPS  
FOR INDOOR INSTALLATION



# TECHNICAL MANUAL

The manufacturer declines all the responsibilities regarding inaccuracies contained in this manual, if due to printing or typing mistakes. The manufacturer reserves the right to apply changes and improvements to the products at any time without notice.

# TABLE OF CONTENTS

<b>GENERAL FEATURES</b> .....	<b>5</b>
Unit description .....	5
Unit identification code .....	5
Description of components .....	6
Control system .....	7
Versions .....	7
<b>ACCESSORIES AND OPTIONAL EQUIPMENT</b> .....	<b>8</b>
Options .....	8
Accessories .....	9
<b>TECHNICAL DATA AND PERFORMANCE - BASE VERSION (VB)</b> .....	<b>10</b>
Technical data .....	10
NET NOMINAL performances - Base setting up (AB) - Standard plants - EUROVENT certified data .....	11
NET NOMINAL performances - Base setting up (AB) - Standard plants .....	11
NET NOMINAL performances - Base setting up (AB) - Radiant plants .....	11
NET NOMINAL performances - Low noise setting up (AS) - Standard plants - EUROVENT certified data .....	12
NET NOMINAL performances - Low noise setting up (AS) - Standard plants .....	12
NET NOMINAL performances - Low noise setting up (AS) - Radiant plants .....	12
COOLING performances .....	13
HEATING performances .....	14
<b>BR - BP UNIT</b> .....	<b>15</b>
Corrective factors .....	15
<b>NOISE LEVELS</b> .....	<b>16</b>
Noise levels .....	16
<b>ELECTRICAL DATA</b> .....	<b>17</b>
Electrical data .....	17
<b>OPERATING LIMITS</b> .....	<b>18</b>
<b>WATER PRESSURE DROP</b> .....	<b>19</b>
<b>WORKING HEAD</b> .....	<b>20</b>
<b>DIMENSIONAL AND PHYSICAL DATA</b> .....	<b>23</b>
Overall dimensions .....	23
Minimum operating area .....	23
Weights .....	24



## GENERAL FEATURES

### Unit description

This series of air-water chillers and heat pumps satisfies the cooling and heating requirements of residential plants of small and medium size.

All the units are suitable for indoor installation and can be applied to fan coil plants, radiant floor plants and high efficiency radiators plants.

The refrigerant circuit, contained in a compartment protected from the air flow to simplify the maintenance operations, is equipped with scroll compressor mounted on damper supports, brazed plate heat exchanger, thermostatic expansion valve, reverse cycle valve, centrifugal fans (plug fan), finned coil made of copper pipes and aluminium louvered fins. The circuit is protected by high and low pressure switches and differential pressure switch on the plate heat exchanger.

The plate heat exchanger and all the hydraulic pipes are thermally insulated in order to avoid condensate generation and to reduce thermal losses.

All the units are equipped with variable speed fans control that allows the units to operate with low outdoor temperatures in cooling and high outdoor temperature in heating and permits to reduce noise emissions in such operating conditions.

The low noise acoustic setting up (AS) is obtained, starting from the base setting up (AB), reducing the rotational speed of the fans and mounting sound jackets on the compressors.

All the units are supplied with an outdoor temperature sensor, already installed on the unit, in order to realize the climatic control.

All the units are provided with a phase presence and correct sequence controller device.

All the units are accurately built and individually tested in the factory. Only electric and hydraulic connections are required for installation.

### Unit identification code

The codes that identify the units and the meaning of the letters used are described below.

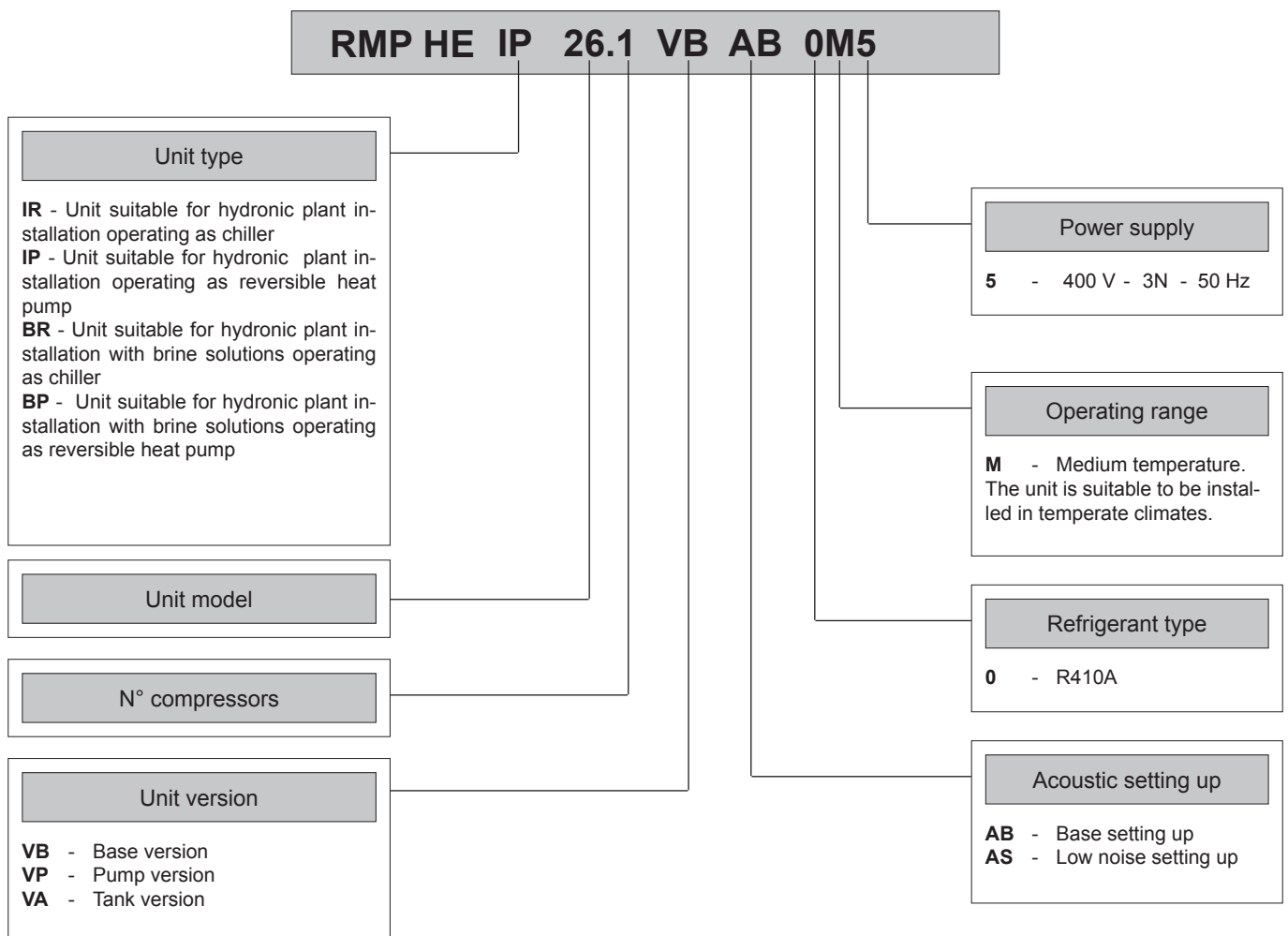

## GENERAL FEATURES

### Description of components

**External structure.** Basement, supporting structure and lateral panels are made of galvanized and painted sheet-steel (colour RAL 7035) to guarantee good resistance to atmospheric agents. Accessibility to internal parts is possible removing the frontal panel. For extraordinary maintenances also the rear panel can be removed.

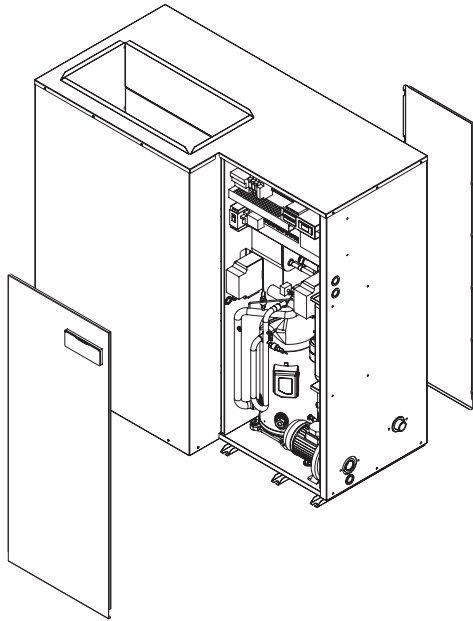

**Refrigerant circuit.** It is contained inside a compartment separated from the air flow to simplify maintenance and control operations.

The hermetic scroll **compressor** (1) is mounted on damper supports and is protected against overtemperatures and overcurrents. It is equipped with an electrical heater, that is activated when the compressor turns off, to keep the compressor crankcase oil temperature high enough to prevent migration of the refrigerant during winter stops and to evaporate any liquid present in the crankcase, in order to prevent possible liquid rushes on starting (only heat pump units, accessory for cooling only units).

The **plant side heat exchanger** (2) is a brazed stainless steel plate heat exchanger, properly insulated to avoid condensate generation and to minimize thermal losses, and protected by a differential pressure switch that detects whatever water flow lack. It is moreover protected against freeze danger by an antifreeze electrical heater.

The **source side heat exchanger** (3) is a finned coil realized with grooved copper pipes and aluminium fins with notched profile to increase the heat exchange coefficient. A tray is obtained in the basement to collect the condensate generated in heating mode.

The **expansion device** (4), a thermostatic expansion valve with external equalizer, allows the unit to adjust itself to the different operating conditions keeping steady the set superheating.

The refrigerant circuit of each unit contains moreover solid core hermetic **filter dryer** (5) to restrain impurity and moisture residuals that could be present in the circuit, **high and low**

**pressure switches** in order to assure the compressor to operate inside the permitted limits, **4 way reverse cycle valve** (6) to allow operating mode change reversing the refrigerant flow (only heat pump models), **liquid receiver** (7) to compensate the different refrigerant charge required in heating and in cooling mode (only heat pump models) and **pressure connections** SAE 5/16" - UNF 1/2" - 20 equipped with pin, gasket and blind nut, as required for the use of R410A refrigerant (they allow the complete check of the refrigerant circuit: compressor inlet pressure, compressor outlet pressure and thermostatic expansion valve upstream pressure).

The **fans** (8) are plug fan type fans equipped with EC direct current motor and embedded inverter. The fans rotational speed is modulated continuously to control the condensation pressure (in cooling) and the evaporation pressure (in heating) in order to optimize the operating conditions of the unit and to reduce noise emissions. The maximum rotational speed can be modified by parameter in order to set the available static head of the fan to the plant requirements.

**Hydraulic circuit.** All the pipes are thermally insulated to avoid condensate generation and minimize thermal losses. The circuit can be equipped with different kind of circulation pump (option). In that case the circuit is also equipped with expansion vessel and air vents. It is also possible to integrate inside the unit a buffer tank arranged as buffer on the flow towards the plant (option). In that case the circuit is equipped not only with expansion vessel and air vents, but also with safety valve, automatic air vent and drain cock.

**Electrical panel.** It contains all the power, control and security components necessary to guarantee the unit to work properly. The unit is managed by a microprocessor controller to which all the electrical loads and the control devices are connected. The user interface, placed on the frontal panel, allows to view and to modify, if necessary, all the parameters of the unit.

All the units are supplied with an outdoor temperature sensor, already installed on the unit, in order to realize the climatic control.

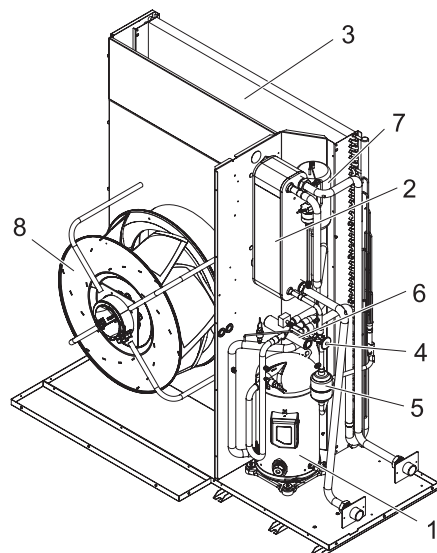

# GENERAL FEATURES

## Control system

The unit is managed by a microprocessor controller to which, through a wiring board, all the electrical loads and the control devices are connected. The user interface is realized by a display and four buttons that allow to view and, if necessary, modify all the operating parameters of the unit. It's available, as an accessory, a remote control that reports all the functionalities of the user interface placed on the unit.

The main functions available are :

- water temperature management (through set point adjustment)
- adaptive function
- climatic control in heating and in cooling mode (automatic set point adjustment according to outdoor air temperature)
- dynamic defrost cycle management according to outdoor air temperature
- alarm memory management and diagnostic
- fans management by means of continuous rotational speed control

- pump management
- integrative electrical heaters management in heating mode (2 step logic)
- compressor and pump operating hours recording
- serial communication through Modbus protocol
- remote stand by
- remote cooling-heating
- general alarm digital output

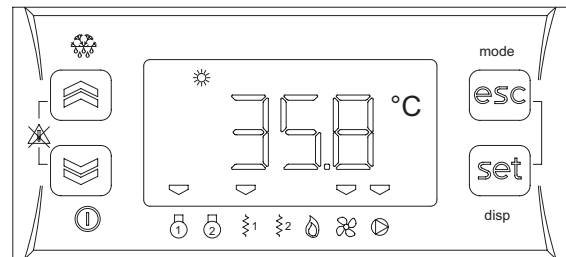

## Versions

Each model can be supplied in three different versions to satisfy the application requirements of the plants. The unit is always supplied assembled, wired and factory tested.

The version is automatically identified by the option "Storing and pumping module" selected.

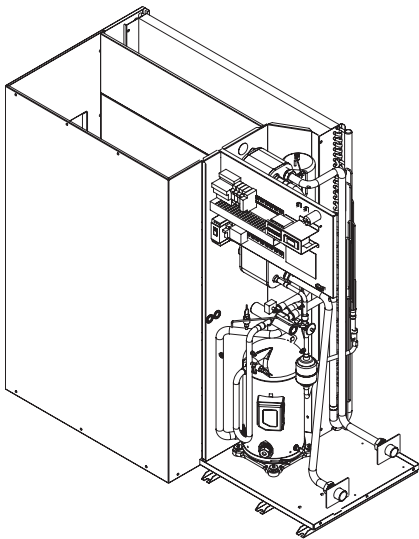

**Base Version - VB**

The unit does not contain neither circulating pump nor tank. Therefore a proper water flow through the plate heat exchanger must be guaranteed to prevent internal safety devices activation. In any case the pump, if properly sized, can be connected to the electrical panel of the unit and managed by the controller of the unit.

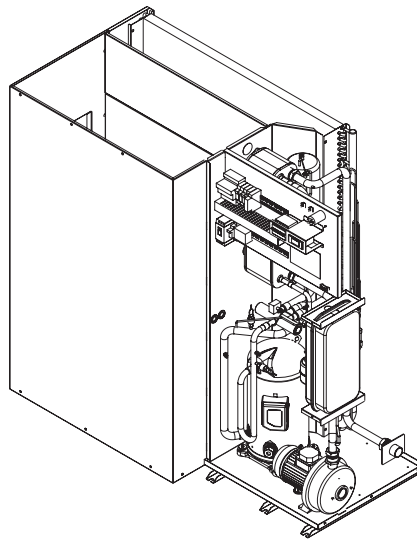

**Pump Version - VP**

The unit contains a circulating pump, air vents, expansion vessel and drain cock.

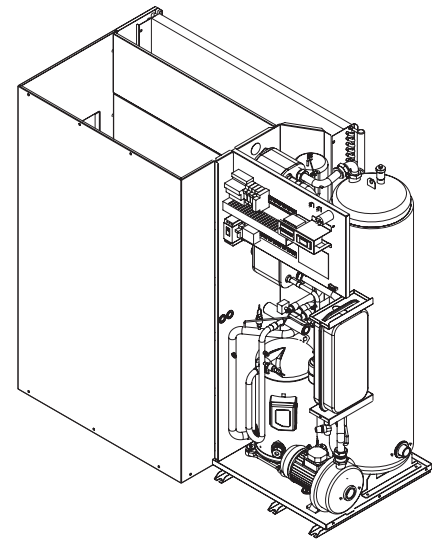

**Tank Version - VA**

The unit contains a tank (arranged as buffer on the flow towards the plant), safety valve, circulating pump, air vents, expansion vessel and drain cock. The tank is also arranged for the installation of antifreeze or integrative electrical heaters.

# ACCESSORIES AND OPTIONAL EQUIPMENT

## Options

<b>Storing and pumping module</b>	<b>Standard pump</b>	Allows the circulation of the water on the plant side.
	<b>High head pump</b>	Allows the circulation of the water on the plant side and guarantees a higher available static head, suitable for high pressure drop plants.
	<b>Modulating pump</b>	Allows the circulation of the water on the plant side with the possibility to set the rotational speed of the pump in order to get the requested flow rate without the necessity to install other setting devices.
	<b>Tank and standard pump</b>	Allows the circulation of the water on the plant side. The thermal inertia of the buffer tank allows to reduce the number of compressor starts and to guarantee a more stable flow temperature.
	<b>Tank and high head pump</b>	Allows the circulation of the water on the plant side and guarantees a higher available static head, suitable for high pressure drop plants. The thermal inertia of the buffer tank allows to reduce the number of compressor starts and to guarantee a more stable flow temperature.
	<b>Tank and modulating pump</b>	Allows the circulation of the water on the plant side with the possibility to set the rotational speed of the pump in order to get the requested flow rate without the necessity to install other setting devices. The thermal inertia of the buffer tank allows to reduce the number of compressor starts and to guarantee a more stable flow temperature.
<b>Electrical heaters</b>	<b>Antifreeze</b>	Activated together with the antifreeze electrical heater of the plate heat exchanger, it has the task to keep the water in the buffer tank at a temperature high enough to avoid ice generation during winter.
	<b>Integrative</b>	Integrate or replace the heating power supplied by the heat pump and are managed by the unit controller with a 2 step logic. They are also activated as antifreeze electrical heaters. Available only for the VA version.
<b>Soft starter</b>		Reduces the compressor start current.
<b>Compressor power factor correction</b>		Allows to reduce the phase shift between the absorbed current and the power supply voltage keeping it above the value of 0,9.
<b>Electrical loads protection</b>	<b>Fuses</b>	Allows to protect the electrical loads with fuses.
	<b>Thermal magnetic circuit breakers</b>	Allows to protect the electrical loads with thermal magnetic circuit breakers simplifying the maintenance operations.

## Hydraulic scheme

**VB unit**

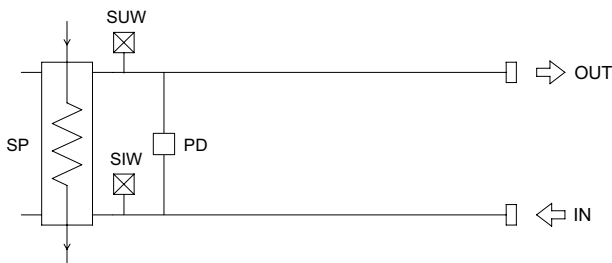

**VA unit**

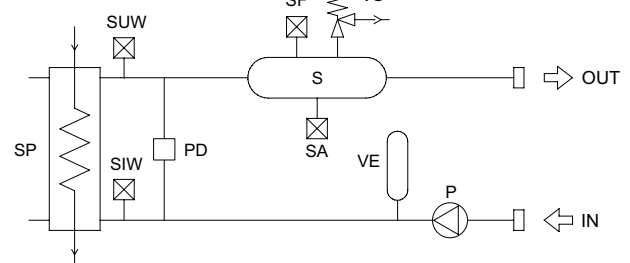

**VP unit**

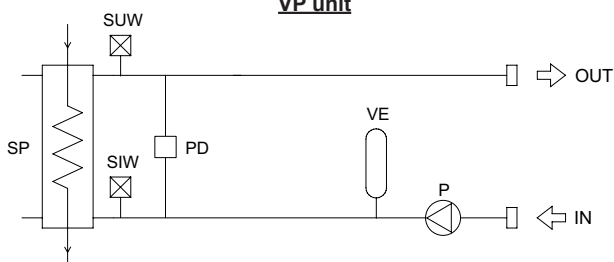

ITEM	DESCRIPTION
P	PUMP
PD	DIFFERENTIAL PRESSURE WATER
S	STORAGE TANK
SA	WATER DRAIN VALVE
SF	VALVOLASFIATO AIR
SIW	PROBE WATER INLET
SP	HEAT EXCHANGER
SUW	PROBE WATER OUTLET
VE	EXPANSION TANK
VS	SAFETY VALVE

## ACCESSORIES AND OPTIONAL EQUIPMENT

### Accessories

#### Supplied accessories

<b>Rubber vibration dampers</b>	Allow to reduce the transmission to the unit support plane of the mechanical vibrations generated by the compressor and by the fans in their normal operating mode.
<b>Coil protection grille</b>	Protects the external surface of the finned coil..
<b>Remote control</b>	It is suitable for wall mounting and reports all the control and visualization functions available on the user interface placed on the unit. It therefore allows the complete remote control of the unit.
<b>Modbus serial interface on RS485</b>	It allows to communicate with the unit controller and to view the operating conditions of the unit through Modbus communication protocol. The RS485 serial line ensures the signal quality up to distances of about 1200 meters (that can be extended by means of proper repeaters).
<b>Programmer clock</b>	It allows the unit to be turned on and off according to a set program, through the digital input available on the unit wiring board (remote stand by).
<b>Phase sequence and voltage controller</b>	It checks not only the presence and correct order of the power supply phases but also the voltage level on each phase and avoid the unit to operate with voltage levels outside the permitted limits.
<b>Water flow switch</b>	Allows to detect the water flow lack through the plate heat exchanger and operates as an integration of the protection offered by the differential pressure switch (standard).

#### Factory mounted accessories

<b>Coil protection grille</b>	Protects the external surface of the finned coil..
<b>Coils protection kit (for transport)</b>	It is a sheet of polystyrene which increases protection of the finned coil during transport.
<b>Casing Kits protection (for transport)</b>	Consisting of 4 profiles cardboard that increase the protection of the casing of the unit during transport.
<b>Modbus serial interface on RS485</b>	It allows to communicate with the unit controller and to view the operating conditions of the unit through Modbus communication protocol. The RS485 serial line ensures the signal quality up to distances of about 1200 meters (that can be extended by means of proper repeaters).
<b>Phase sequence and voltage controller</b>	It checks not only the presence and correct order of the power supply phases but also the voltage level on each phase and avoid the unit to operate with voltage levels outside the permitted limits.
<b>High and low pressure gauges</b>	2 pressure gauges allow visualization of high and low refrigerant gas pressure.
<b>Pressure transducer*</b>	It consists of a transducer, which allows operation of the control condensation, evaporation and defrost by reading the pressure.
<b>Crankcase heaters compressor oil</b>	(standard for IP and BP units, accessory IR and BR units ) consist of electrical heaters heating oil compressors.

#### NOTES

\* This accessory can be selected only for units with modulating fan control.

## TECHNICAL DATA AND PERFORMANCE - BASE VERSION (VB)

### Technical data

Frame	1			2			
Model	19.1	22.1	26.1	30.1	35.1	40.1	U.M.
Power supply	400 - 3N - 50	400 - 3N - 50	400 - 3N - 50	400 - 3N - 50	400 - 3N - 50	400 - 3N - 50	V-ph-Hz

<b>Refrigerant</b>							
Type	R410A	R410A	R410A	R410A	R410A	R410A	-
<b>Compressor</b>							
Type	scroll	scroll	scroll	scroll	scroll	scroll	-
Quantity	1	1	1	1	1	1	n°
Power steps	0 - 100	0 - 100	0 - 100	0 - 100	0 - 100	0 - 100	%
<b>Plant side heat exchanger</b>							
Type	stainless steel brazed plates	stainless steel brazed plates	stainless steel brazed plates	stainless steel brazed plates	stainless steel brazed plates	stainless steel brazed plates	-
Quantity	1	1	1	1	1	1	n°
<b>Source side heat exchanger</b>							
Type	finned coil	finned coil	finned coil	finned coil	finned coil	finned coil	-
Quantity	1	1	1	1	1	1	n°
<b>Fans</b>							
Type	plug fan with EC motor and embedded inverter	plug fan with EC motor and embedded inverter	plug fan with EC motor and embedded inverter	plug fan with EC motor and embedded inverter	plug fan with EC motor and embedded inverter	plug fan with EC motor and embedded inverter	-
Quantity	1	1	1	1	1	1	n°
Diameter	630	630	630	630	630	630	mm
Maximum rotational speed	1200	1200	1200	1200	1200	1200	rpm
Total installed power	2,8	2,8	2,8	2,8	2,8	2,8	kW
<b>Plant side hydraulic circuit</b>							
Expansion vessel volume VP - VA	10	10	10	10	10	10	l
Tank volume - VA	85	85	85	85	85	85	l
Safety valve set * - VP - VA	3	3	3	3	3	3	bar
<b>Standard pump (option)</b>							
Type	centrifugal pump	centrifugal pump	centrifugal pump	centrifugal pump	centrifugal pump	centrifugal pump	-
Installed power	0,6	0,6	0,6	0,8	0,8	0,8	kW
<b>High head pump (option)</b>							
Type	centrifugal pump	centrifugal pump	centrifugal pump	centrifugal pump	centrifugal pump	centrifugal pump	-
Installed power	0,9	0,9	0,9	1,6	1,6	1,6	kW
<b>Modulating pump (option)</b>							
Type	centrifugal pump with inverter	centrifugal pump with inverter	centrifugal pump with inverter	centrifugal pump with inverter	centrifugal pump with inverter	centrifugal pump with inverter	-
Installed power	0,6	0,6	0,6	0,8	0,8	0,8	kW
<b>Integrative electrical heaters in the tank (option)</b>							
Installed power	6,6	6,6	6,6	6,6	6,6	6,6	kW
Power steps	2	2	2	2	2	2	n°

### NOTES

\*: Standard version for VA, to be installed by the customer for VP version.

## TECHNICAL DATA AND PERFORMANCE - BASE VERSION (VB)

### NET NOMINAL performances - Base setting up (AB) - Standard plants - EUROVENT certified data

Frame		1			2				
Model		19.1	22.1	26.1	30.1	35.1	40.1	U.M.	
IR	<b>Cooling A35W7</b> ( source : air in 35°C d.b. / plant : water in 12°C out 7°C )								
	Cooling capacity	20,1	22,3	26,1	31,5	36,6	41,3	kW	
	Power input	6,51	7,15	8,29	10,3	11,9	13,5	kW	
	EER	3,09	3,12	3,15	3,06	3,08	3,06	W/W	
	ESEER	3,44	3,48	3,51	3,44	3,45	3,45	W/W	
	Water flow rate plant side	3466	3844	4496	5439	6315	7138	l/h	
	Pressure drops plant side	26	32	26	37	32	41	kPa	
IP	<b>Cooling A35W7</b> ( source : air in 35°C d.b. / plant : water in 12°C out 7°C )								
	Cooling capacity	19,7	21,9	25,6	30,9	35,9	40,5	kW	
	Power input	6,45	7,08	8,20	10,2	11,8	13,4	kW	
	EER	3,05	3,09	3,12	3,03	3,04	3,02	W/W	
	ESEER	3,40	3,46	3,47	3,42	3,40	3,40	W/W	
	Water flow rate plant side	3398	3775	4410	5337	6194	7001	l/h	
		Pressure drops plant side	25	31	25	36	31	39	kPa
	<b>Heating A7W45</b> ( source : air in 7°C d.b. 6°C w.b. / plant : water in 40°C out 45°C )								
	Heating capacity	21,2	23,5	27,4	33,3	38,6	43,8	kW	
	Power input	6,21	6,82	7,89	9,79	11,3	12,9	kW	
	COP	3,41	3,45	3,47	3,40	3,42	3,40	W/W	
	Water flow rate plant side	3603	3995	4661	5651	6556	7427	l/h	
	Pressure drops plant side	28	34	28	40	34	43	kPa	

### NET NOMINAL performances - Base setting up (AB) - Standard plants

Frame		1			2			
Model		19.1	22.1	26.1	30.1	35.1	40.1	U.M.
IP	<b>Heating A2W45</b> ( source : air in 2°C d.b. 1°C w.b. / plant : water in 40°C out 45°C )							
	Heating capacity	17,5	19,5	22,7	27,5	31,9	36,2	kW
	Power input	6,12	6,70	7,78	9,62	11,1	12,7	kW
	COP	2,86	2,91	2,92	2,86	2,87	2,85	W/W
	Water flow rate plant side	2971	3312	3859	4678	5430	6147	l/h
		Pressure drops plant side	19	24	19	28	24	30

Data declared according to **EN 14511**. The values are referred to units without options and accessories.

### NET NOMINAL performances - Base setting up (AB) - Radiant plants

Frame		1			2				
Model		19.1	22.1	26.1	30.1	35.1	40.1	U.M.	
IR	<b>Cooling A35W18</b> ( source : air in 35°C d.b. / plant : water in 23°C out 18°C )								
	Cooling capacity	26,1	28,9	33,9	40,8	47,4	53,5	kW	
	Power input	6,67	7,35	8,49	10,60	12,2	13,9	kW	
	EER	3,91	3,93	3,99	3,85	3,89	3,85	-	
	Water flow rate plant side	4517	4998	5856	7076	8209	9291	l/h	
		Pressure drops plant side	43	52	43	62	53	67	kPa
IP	<b>Cooling A35W18</b> ( source : air in 35°C d.b. / plant : water in 23°C out 18°C )								
	Cooling capacity	25,5	28,4	33,2	40,0	46,5	52,5	kW	
	Power input	6,60	7,27	8,40	10,5	12,1	13,7	kW	
	EER	3,86	3,91	3,95	3,81	3,84	3,83	-	
	Water flow rate plant side	4414	4912	5736	6938	8055	9102	l/h	
		Pressure drops plant side	41	50	41	59	51	64	kPa
	<b>Heating A7W35</b> ( source : air in 7°C d.b. 6°C w.b. / plant : water in 30°C out 35°C )								
	Heating capacity	21,6	24,0	28,0	34,0	39,4	44,7	kW	
	Power input	5,24	5,76	6,66	8,28	9,57	10,9	kW	
	COP	4,12	4,17	4,20	4,11	4,12	4,10	-	
	Water flow rate plant side	3686	4097	4783	5794	6720	7611	l/h	
		Pressure drops plant side	29	36	29	42	36	46	kPa
	<b>Heating A2W35</b> ( source : air in 2°C d.b. 1°C w.b. / plant : water in 30°C out 35°C )								
	Heating capacity	17,9	19,9	23,3	28,2	32,6	37,1	kW	
	Power input	5,15	5,64	6,54	8,10	9,39	10,7	kW	
COP	3,48	3,53	3,56	3,48	3,47	3,47	-		
Water flow rate plant side	3051	3394	3977	4817	5571	6326	l/h		
	Pressure drops plant side	20	25	21	30	25	32	kPa	

Data declared according to **EN 14511**. The values are referred to units without options and accessories.

Performances referred to an available static head of the fan equal to 150 Pa.

## TECHNICAL DATA AND PERFORMANCE - BASE VERSION (VB)

### NET NOMINAL performances - Low noise setting up (AS) - Standard plants - EUROVENT certified data

Frame		1			2			
Model		19.1	22.1	26.1	30.1	35.1	40.1	U.M.
IR	<b>Cooling A35W7</b> ( source : air in 35°C d.b. / plant : water in 12°C out 7°C )							
	Cooling capacity	19,3	21,4	25,1	30,3	35,2	39,8	kW
	Power input	7,02	7,71	8,94	11,1	12,8	14,4	kW
	EER	2,75	2,78	2,81	2,73	2,75	2,76	W/W
	ESEER	3,06	3,10	3,12	3,07	3,08	3,09	W/W
	Water flow rate plant side	3329	3689	4324	5234	6074	6864	l/h
	Pressure drops plant side	24	29	24	35	30	38	kPa
IP	<b>Cooling A35W7</b> ( source : air in 35°C d.b. / plant : water in 12°C out 7°C )							
	Cooling capacity	18,9	21,0	24,6	29,7	34,5	39,0	kW
	Power input	6,95	7,63	8,84	11,0	12,7	14,3	kW
	EER	2,72	2,75	2,78	2,70	2,72	2,73	W/W
	ESEER	3,03	3,07	3,09	3,04	3,05	3,05	W/W
	Water flow rate plant side	3260	3621	4238	5131	5954	6726	l/h
	Pressure drops plant side	23	28	23	34	29	36	kPa
	<b>Heating A7W45</b> ( source : air in 7°C d.b. 6°C w.b. / plant : water in 40°C out 45°C )							
	Heating capacity	20,1	22,3	26,1	31,7	36,7	41,7	kW
	Power input	5,95	6,54	7,56	9,38	10,9	12,4	kW
	COP	3,38	3,41	3,45	3,38	3,37	3,36	W/W
	Water flow rate plant side	3415	3790	4439	5378	6232	7069	l/h
	Pressure drops plant side	25	31	25	36	31	40	kPa

### NET NOMINAL performances - Low noise setting up (AS) - Standard plants

Frame		1			2			
Model		19.1	22.1	26.1	30.1	35.1	40.1	U.M.
IP	<b>Heating A2W45</b> ( source : air in 2°C d.b. 1°C w.b. / plant : water in 40°C out 45°C )							
	Heating capacity	16,5	18,5	21,6	26,1	30,2	34,3	kW
	Power input	5,87	6,43	7,46	9,22	10,7	12,1	kW
	COP	2,81	2,88	2,90	2,83	2,82	2,83	W/W
	Water flow rate plant side	2817	3142	3671	4439	5139	5839	l/h
	Pressure drops plant side	17	22	18	25	22	28	kPa

Data declared according to **EN 14511**. The values are referred to units without options and accessories.

### NET NOMINAL performances - Low noise setting up (AS) - Radiant plants

Frame		1			2			
Model		19.1	22.1	26.1	30.1	35.1	40.1	U.M.
IR	<b>Cooling A35W18</b> ( source : air in 35°C d.b. / plant : water in 23°C out 18°C )							
	Cooling capacity	25,0	27,8	32,6	39,3	45,6	51,5	kW
	Power input	7,18	7,91	9,14	11,4	13,1	14,8	kW
	EER	3,48	3,51	3,57	3,45	3,48	3,48	-
	Water flow rate plant side	4328	4809	5633	6818	7900	8930	l/h
	Pressure drops plant side	40	48	40	57	49	62	kPa
IP	<b>Cooling A35W18</b> ( source : air in 35°C d.b. / plant : water in 23°C out 18°C )							
	Cooling capacity	24,5	27,2	31,9	38,6	44,8	50,5	kW
	Power input	7,10	7,81	9,04	11,2	12,9	14,7	kW
	EER	3,45	3,48	3,53	3,45	3,47	3,44	-
	Water flow rate plant side	4242	4706	5513	6681	7745	8759	l/h
	Pressure drops plant side	38	47	38	55	47	60	kPa
	<b>Heating A7W35</b> ( source : air in 7°C d.b. 6°C w.b. / plant : water in 30°C out 35°C )							
	Heating capacity	20,5	22,8	26,6	32,3	37,4	42,5	kW
	Power input	5,02	5,52	6,38	7,92	9,17	10,5	kW
	COP	4,08	4,13	4,17	4,08	4,08	4,05	-
	Water flow rate plant side	3497	3891	4543	5503	6377	7234	l/h
	Pressure drops plant side	26	32	27	38	33	42	kPa
	<b>Heating A2W35</b> ( source : air in 2°C d.b. 1°C w.b. / plant : water in 30°C out 35°C )							
	Heating capacity	16,9	18,9	22,1	26,7	31,0	35,2	kW
	Power input	4,93	5,42	6,28	7,76	9,00	10,3	kW
	COP	3,43	3,49	3,52	3,44	3,44	3,42	-
	Water flow rate plant side	2897	3223	3771	4560	5297	6000	l/h
	Pressure drops plant side	19	23	19	27	23	29	kPa

Data declared according to **EN 14511**. The values are referred to units without options and accessories.

Performances referred to an available static head of the fan equal to 150 Pa.

# TECHNICAL DATA AND PERFORMANCE - BASE VERSION (VB)

## COOLING performances

The graphs allow to get the corrective factors to be applied to the nominal performances in order to obtain the real performances in the selected operating conditions. For the "Operation limits" of the unit refer to the section limits.

The reference nominal condition is: **A35W7** (source : air in 35°C d.b. / plant : water in 12°C out 7°C)

### Cooling capacity

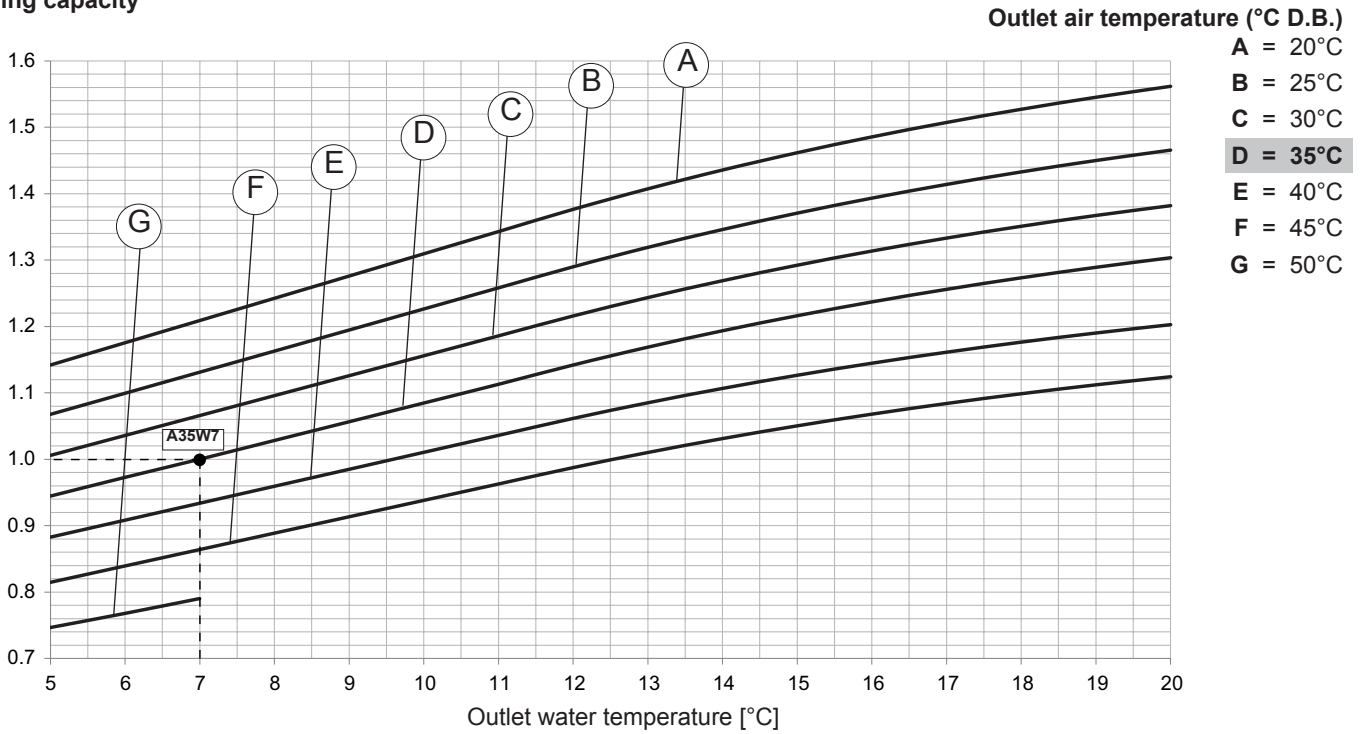

### Total power input

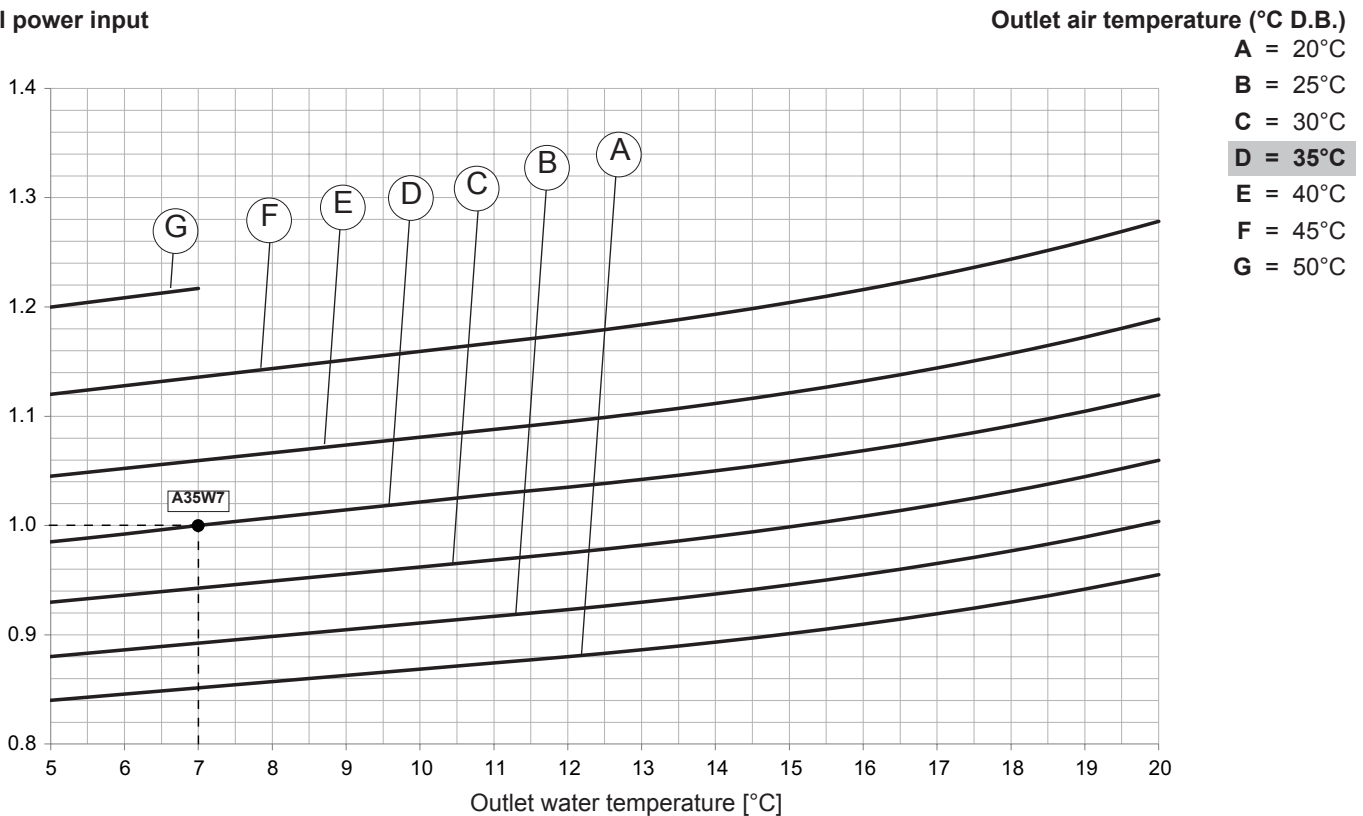

The standard performances refer to a 5°C temperature difference between the water entering and leaving the heat exchanger and to operation of the unit with all fans at nominal or maximum speed. A  $0.44 \times 10^{-4}$  m<sup>2</sup> K/W fouling factor has also been considered with the unit installed at zero meters above sea level (Pb = 1013mbar).

# TECHNICAL DATA AND PERFORMANCE - BASE VERSION (VB)

## HEATING performances

The graphs allow to get the corrective factors to be applied to the nominal performances in order to obtain the real performances in the selected operating conditions. For the "Operation limits" of the unit refer to the section limits.

The reference nominal condition is: **A7W45** (source : air in 7°C d.b. 6°C w.b. / plant : water in 40°C out 45°C)

### Heating capacity

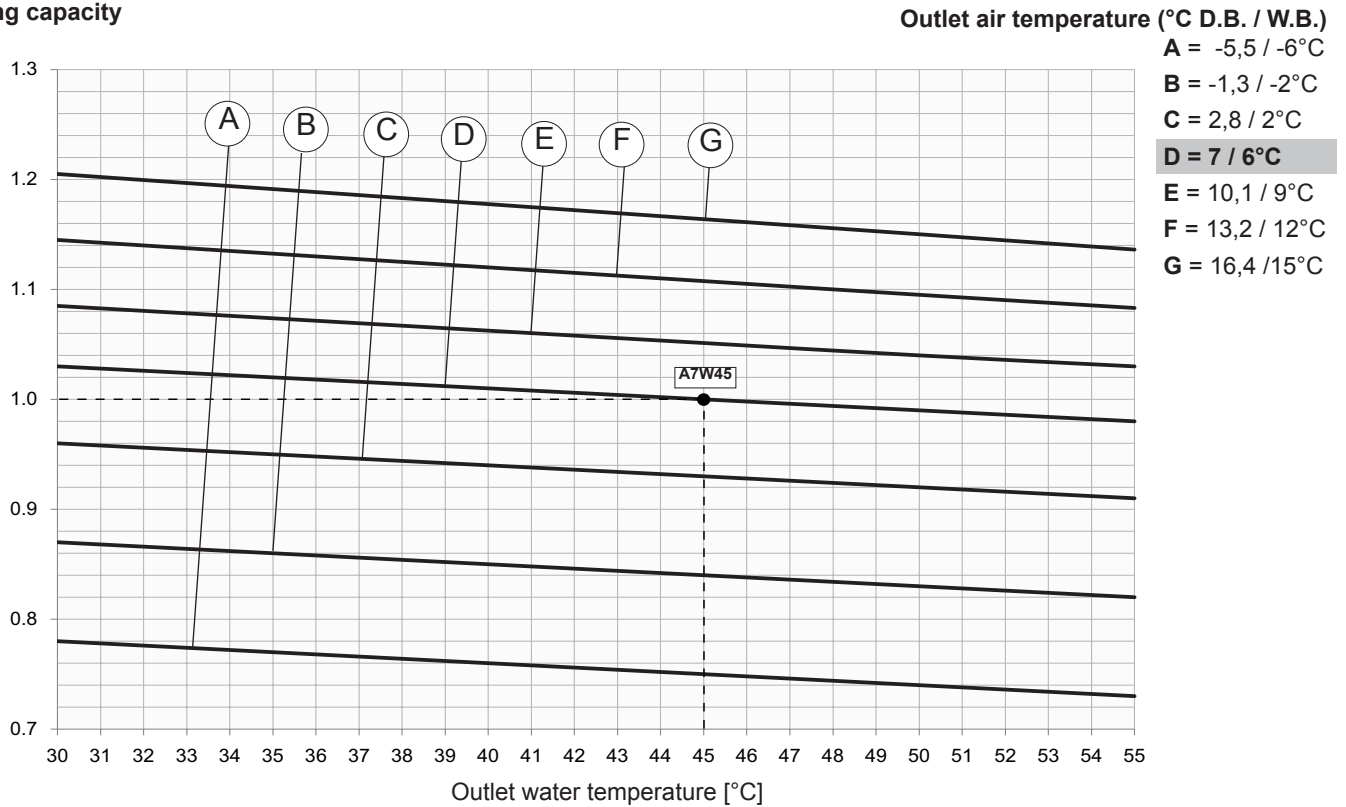

### Total power input

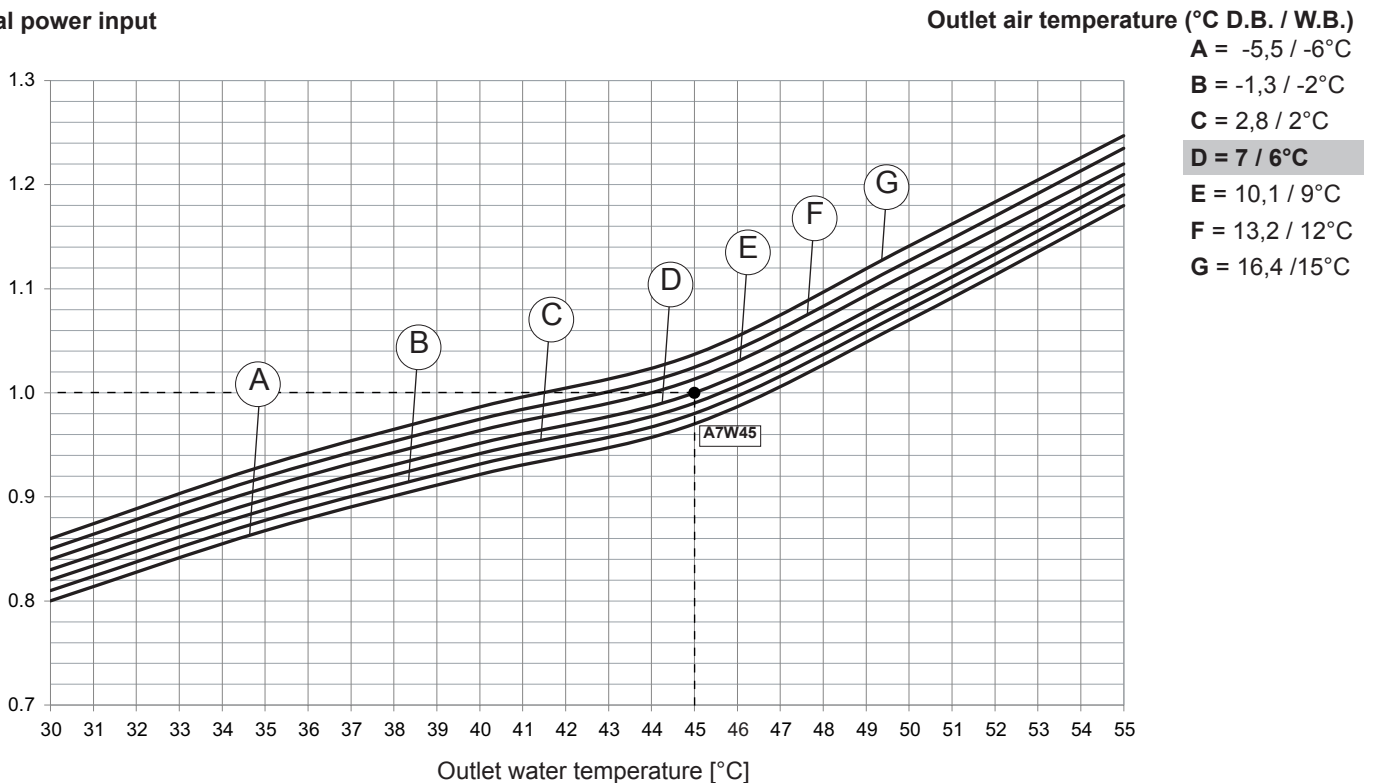

The standard performances refer to a 5°C temperature difference between the water entering and leaving the heat exchanger and to operation of the unit with all fans at nominal or maximum speed. A  $0.44 \times 10^{-4}$  m<sup>2</sup> K/W fouling factor has also been considered with the unit installed at zero meters above sea level (Pb = 1013mbar).

**NOTE** For air temperatures of less than 7°C, the heating capacity is declared without considering the effect of the defrosting, strictly correlated with the humidity in the outdoor air.

## BR - BP UNIT

### Corrective factors

Correction factors to apply to the basic version data.

#### ETHYLENE GLYCOL

Percentage Of glycol in mass / volume	20 / 18,1								
Freezing point [°C]	-8								
Produced water temperature	4	2	0	-2	-4	-6	-8	-10	-12
CCPF - Cooling capacity	0,912	0,855	0,798	0,738	0,683	-	-	-	-
CCPA - Power input	0,967	0,957	0,947	0,927	0,897	-	-	-	-
CCQA - Water flow rate	1,071	1,072	1,073	1,075	1,076	-	-	-	-
CCDP - Pressure drop	1,090	1,095	1,100	1,110	1,120	-	-	-	-

Percentage Of glycol in mass / volume	30 / 27,7								
Freezing point [°C]	-14								
Produced water temperature	4	2	0	-2	-4	-6	-8	-10	-12
CCPF - Cooling capacity	0,899	0,842	0,785	0,725	0,670	0,613	0,562	-	-
CCPA - Power input	0,960	0,950	0,940	0,920	0,890	0,870	0,840	-	-
CCQA - Water flow rate	1,106	1,107	1,108	1,109	1,110	1,111	1,112	-	-
CCDP - Pressure drop	1,140	1,145	1,150	1,155	1,160	1,175	1,190	-	-

Percentage Of glycol in mass / volume	40 / 37,5								
Freezing point [°C]	-22								
Produced water temperature	4	2	0	-2	-4	-6	-8	-10	-12
CCPF - Cooling capacity	0,884	0,827	0,770	0,710	0,655	0,598	0,547	0,490	0,437
CCPA - Power input	0,880	0,870	0,860	0,840	0,810	0,790	0,760	0,724	0,686
CCQA - Water flow rate	1,150	1,151	1,153	1,154	1,155	1,157	1,158	1,159	1,161
CCDP - Pressure drop	1,190	1,195	1,200	1,210	1,220	1,235	1,250	1,269	1,290

#### PROPYLENE GLYCOL

Percentage Of glycol in mass / volume	20 / 19,4								
Freezing point [°C]	-7								
Produced water temperature	4	2	0	-2	-4	-6	-8	-10	-12
CCPF - Cooling capacity	0,874	0,807	0,740	0,690	0,641	-	-	-	-
CCPA - Power input	0,945	0,935	0,925	0,900	0,875	-	-	-	-
CCQA - Water flow rate	1,037	1,038	1,039	1,039	1,040	-	-	-	-
CCDP - Pressure drop	1,110	1,115	1,120	1,130	1,140	-	-	-	-

Percentage Of glycol in mass / volume	30 / 29,4								
Freezing point [°C]	-13								
Produced water temperature	4	2	0	-2	-4	-6	-8	-10	-12
CCPF - Cooling capacity	0,869	0,799	0,729	0,680	0,630	0,583	0,536	-	-
CCPA - Power input	0,935	0,923	0,910	0,888	0,865	0,838	0,810	-	-
CCQA - Water flow rate	1,072	1,071	1,070	1,069	1,069	1,068	1,067	-	-
CCDP - Pressure drop	1,160	1,175	1,190	1,200	1,210	1,255	1,300	-	-

Percentage Of glycol in mass / volume	40 / 39,6								
Freezing point [°C]	-21								
Produced water temperature	4	2	0	-2	-4	-6	-8	-10	-12
CCPF - Cooling capacity	0,848	0,784	0,719	0,670	0,620	0,570	0,520	0,478	0,438
CCPA - Power input	0,865	0,855	0,845	0,820	0,795	0,773	0,750	0,714	0,680
CCQA - Water flow rate	1,116	1,114	1,112	1,110	1,108	1,107	1,105	1,103	1,101
CCDP - Pressure drop	1,230	1,275	1,320	1,375	1,430	1,500	1,570	1,642	1,724

Based on leaving water temperature of the evaporator and condensing temperature = 7°C extract Cooling Capacity (kWf) and Compressors Power Input (kW<sub>a</sub>).

Based on type and percentage of glycol extract CCPF, CCPA, CCQA, CCDP.

Then calculate.

$$Pf_{brine} = kWf \times CCPF$$

$$Pass_{CP_{brine}} = kW_a \times CCPA$$

Then calculate brine flow rate:

$$Q_{brine_{evap}} [l/s] = CCQA \times (Pf_{brine} [kW] \times 0.86 / \Delta T_{brine}) / 3.6$$

where  $\Delta T_{brine}$  is the difference between inlet-outlet evaporator water temperature:

$$\Delta T_{brine} = T_{in_{evap_{brine}}} - T_{out_{evap_{brine}}}$$

With this brine flow rate enter in abscissa on the water pressure drop of the evaporator then you have  $Dp_{app}$ .

Finally you can calculate the actual pressure drop of the brine on evaporator side:

$$Dp_{evap_{brine}} = CCDP \times Dp_{app}$$

## NOISE LEVELS

### Noise levels

Model	Sound power levels [dB] by octave bands [Hz]								Sound power level		Sound pressure level		
	63	125	250	500	1000	2000	4000	8000	[dB]	[dB(A)] <sup>(E)</sup>	at 1 metre [dB(A)]	at 5 metres [dB(A)]	at 10 metres [dB(A)]
<b>Base setting up (AB)</b>													
<b>19.1</b>	85,1	79,4	74,3	73,2	71,3	68,4	62,6	57,6	87	76	60	50	45
<b>22.1</b>	85,3	79,6	74,5	73,4	71,5	68,6	62,8	57,8	87	76	60	50	45
<b>26.1</b>	86,3	80,6	75,5	74,4	72,5	69,6	63,8	58,8	88	77	61	51	46
<b>30.1</b>	89,3	83,6	78,5	77,4	75,5	72,6	66,8	61,8	91	80	64	54	49
<b>35.1</b>	89,8	84,1	79,0	77,9	76,0	73,1	67,3	62,3	92	81	65	55	49
<b>40.1</b>	90,3	84,6	79,5	78,4	76,5	73,6	67,8	62,8	92	81	65	55	50
<b>Low noise setting up (AS)</b>													
<b>19.1</b>	83,1	77,4	72,3	71,2	69,3	66,4	60,6	55,6	85	74	58	48	43
<b>22.1</b>	83,3	77,6	72,5	71,4	69,5	66,6	60,8	55,8	85	74	58	48	43
<b>26.1</b>	84,3	78,6	73,5	72,4	70,5	67,6	61,8	56,8	86	75	59	49	44
<b>30.1</b>	87,3	81,6	76,5	75,4	73,5	70,6	64,8	59,8	89	78	62	52	47
<b>35.1</b>	87,8	82,1	77,0	75,9	74,0	71,1	65,3	60,3	90	79	63	53	47
<b>40.1</b>	88,3	82,6	77,5	76,4	74,5	71,6	65,8	60,8	90	79	63	53	48

#### Reference conditions

Performances referred to units operating in cooling mode at nominal conditions A35W7.

Unit placed in free field on reflecting surface (directional factor equal to 2).

Unit ducted on the suction and on the flow side for 2 meters.

The sound power level is measured according to ISO 3744 standard.

The sound pressure level is calculated according to ISO 3744 and is referred to a distance of 1/5/10 metres from the external surface of the unit.

(E) : EUROVENT certified data.

## ELECTRICAL DATA

### Electrical data

Frame	1			2			
Model	19.1	22.1	26.1	30.1	35.1	40.1	U.M.

#### Unit

Power supply		400-3N-50	400-3N-50	400-3N-50	400-3N-50	400-3N-50	400-3N-50	V-ph-Hz
F.L.A.	Maximum total current input	18,7	20,5	22,0	24,4	26,8	30,8	A
F.L.I.	Maximum total power input	11,3	12,8	14,1	15,5	17,0	19,3	kW
M.I.C.	Maximum total start current	118	128	141	158	162	193	A
	Maximum total start current with soft starter (option)	61	67	74	85	87	106	A

#### Units with pumping module STD

Power supply		400-3N-50	400-3N-50	400-3N-50	400-3N-50	400-3N-50	400-3N-50	V-ph-Hz
F.L.A.	Maximum total current input	20,2	22,0	23,5	26,0	28,4	32,4	A
F.L.I.	Maximum total power input	11,9	13,4	14,7	16,3	17,8	20,1	kW
M.I.C.	Maximum total start current	120	130	143	160	164	195	A
	Maximum total start current with soft starter (option)	62	68	76	86	89	107	A

#### Units with pumping module HP1

Power supply		400-3N-50	400-3N-50	400-3N-50	400-3N-50	400-3N-50	400-3N-50	V-ph-Hz
F.L.A.	Maximum total current input	20,4	22,2	23,7	27,4	29,8	33,8	A
F.L.I.	Maximum total power input	12,2	13,6	15,0	17,1	18,6	20,9	kW
M.I.C.	Maximum total start current	120	130	143	161	165	196	A
	Maximum total start current with soft starter (option)	62	68	76	88	90	109	A

#### Integrative electrical heaters standard in the tank (option)

Power supply		400-3-50	400-3-50	400-3-50	400-3-50	400-3-50	400-3-50	V-ph-Hz
F.L.A.	Maximum total current input	9,5	9,5	9,5	9,5	9,5	9,5	A
F.L.I.	Maximum total power input	6,6	6,6	6,6	6,6	6,6	6,6	kW

#### Compressor

Power supply		400-3-50	400-3-50	400-3-50	400-3-50	400-3-50	400-3-50	V-ph-Hz
F.L.A.	Maximum total current input	14,6	16,4	17,9	20,3	22,7	26,7	A
F.L.I.	Maximum total power input	8,6	10,1	11,4	12,8	14,3	16,6	kW
L.R.A.	Maximum total start current	101	111	124	141	145	176	A
	Maximum total start current with soft starter (option)	61	67	74	85	87	106	A

#### Fan

Power supply		400-3-50	400-3-50	400-3-50	400-3-50	400-3-50	400-3-50	V-ph-Hz
F.L.A.	Maximum total current input	4,10	4,10	4,10	4,10	4,10	4,10	A
F.L.I.	Maximum total power input	2,70	2,70	2,70	2,70	2,70	2,70	kW
L.R.A.	Start current	17	17	17	17	17	17	A

#### Standard THREE-PHASE pump (option)

Power supply		400-3-50	400-3-50	400-3-50	400-3-50	400-3-50	400-3-50	V-ph-Hz
F.L.A.	Maximum total current input	1,45	1,45	1,45	1,58	1,58	1,58	A
F.L.I.	Maximum total power input	0,61	0,61	0,61	0,82	0,82	0,82	kW
L.R.A.	Start current	6,3	6,3	6,3	9,4	9,4	9,4	A

#### High head THREE-PHASE pump (option)

Power supply		400-3-50	400-3-50	400-3-50	400-3-50	400-3-50	400-3-50	V-ph-Hz
F.L.A.	Maximum total current input	1,65	1,65	1,65	3,00	3,00	3,00	A
F.L.I.	Maximum total power input	0,88	0,88	0,88	1,60	1,60	1,60	kW
L.R.A.	Start current	9,9	9,9	9,9	16,3	16,3	16,3	A

## OPERATING LIMITS

The table below lists the operating limits within which correct operation of the units is guaranteed, depending on the Version and Operating Mode available for each type of unit.  
Remember that in Heat Pump units, heat recovery only takes place during operation in the cooling mode.

Thermal gradient of the water		Limit value
Minimum	°C	3
Maximum	°C	8

Verify that water flow rate is inside the admissible limits.

**NOTE:** the admissible limits for water flow rate on heat exchangers are indicated under the related pressure drop graph (see section "water pressure drop"). If the unit is equipped with pumping module the admissible limits are indicated under the related working head graph (see section "working head").

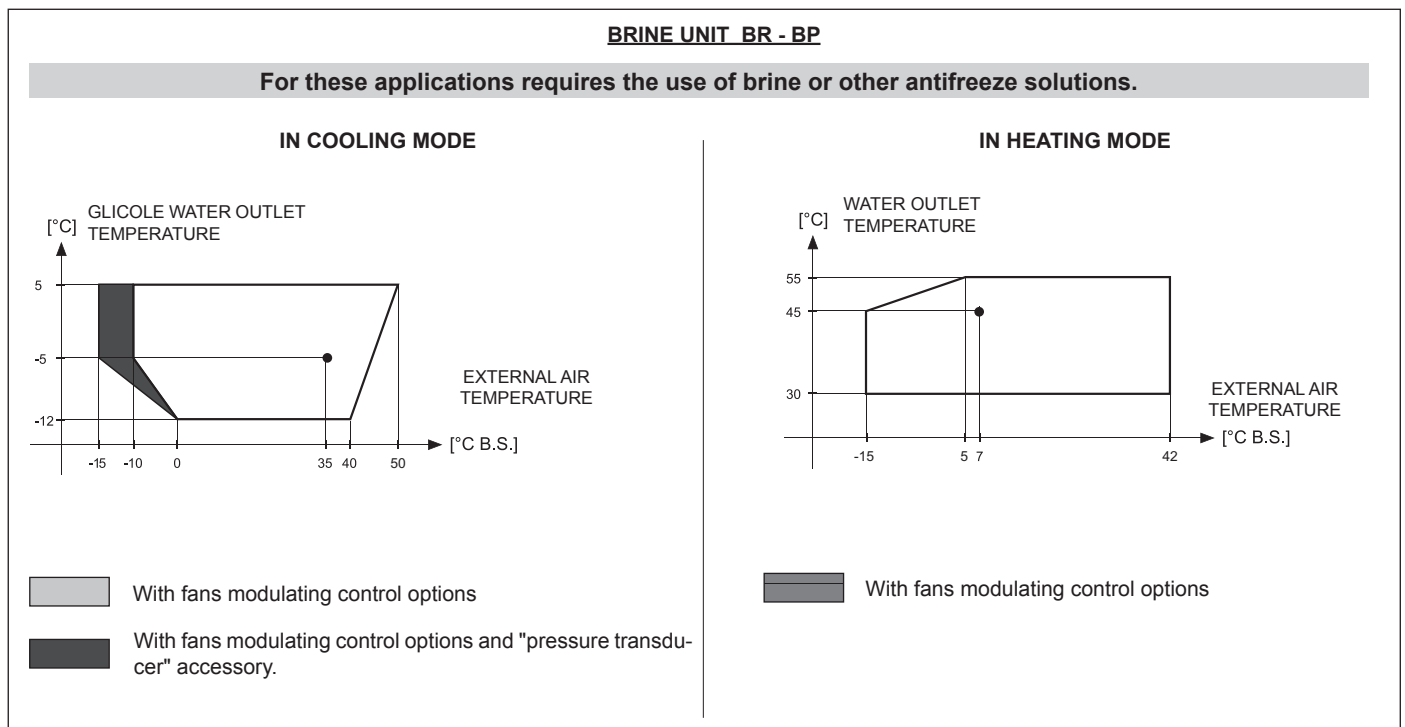
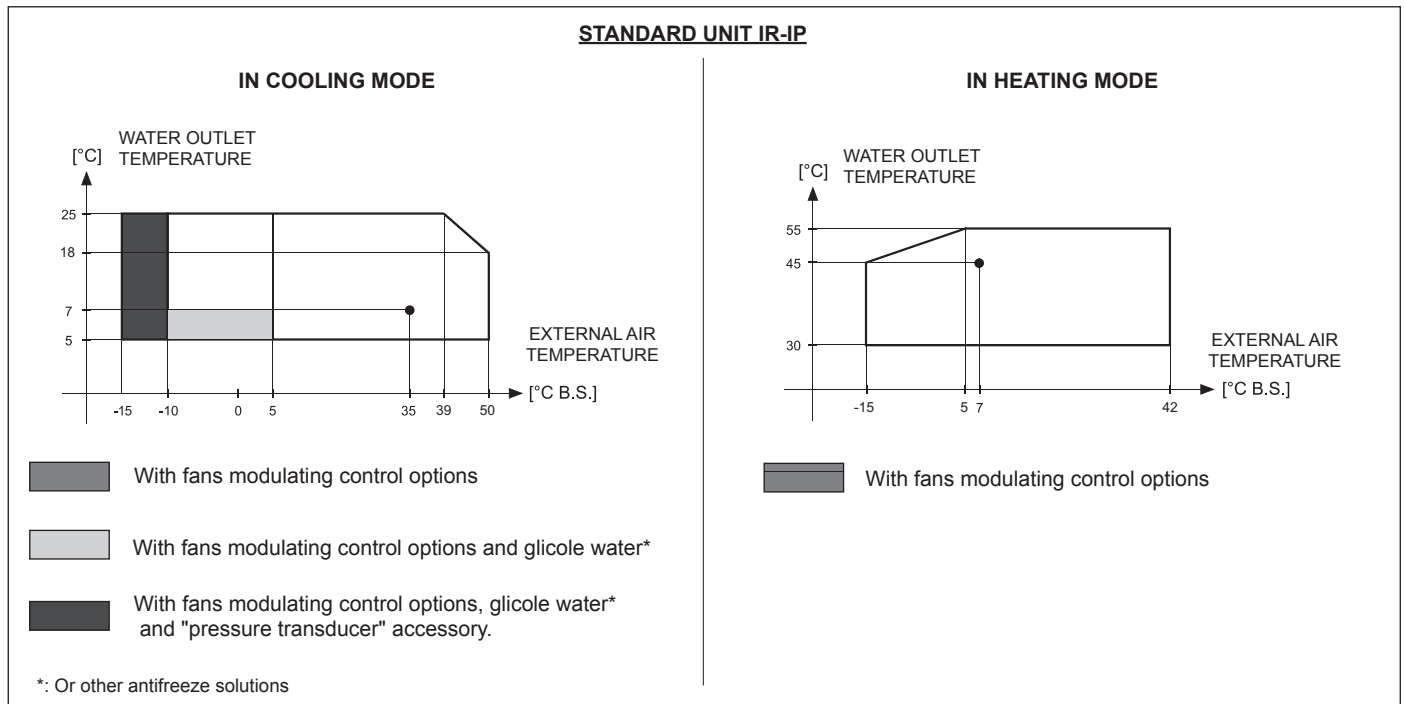

# WATER PRESSURE DROP

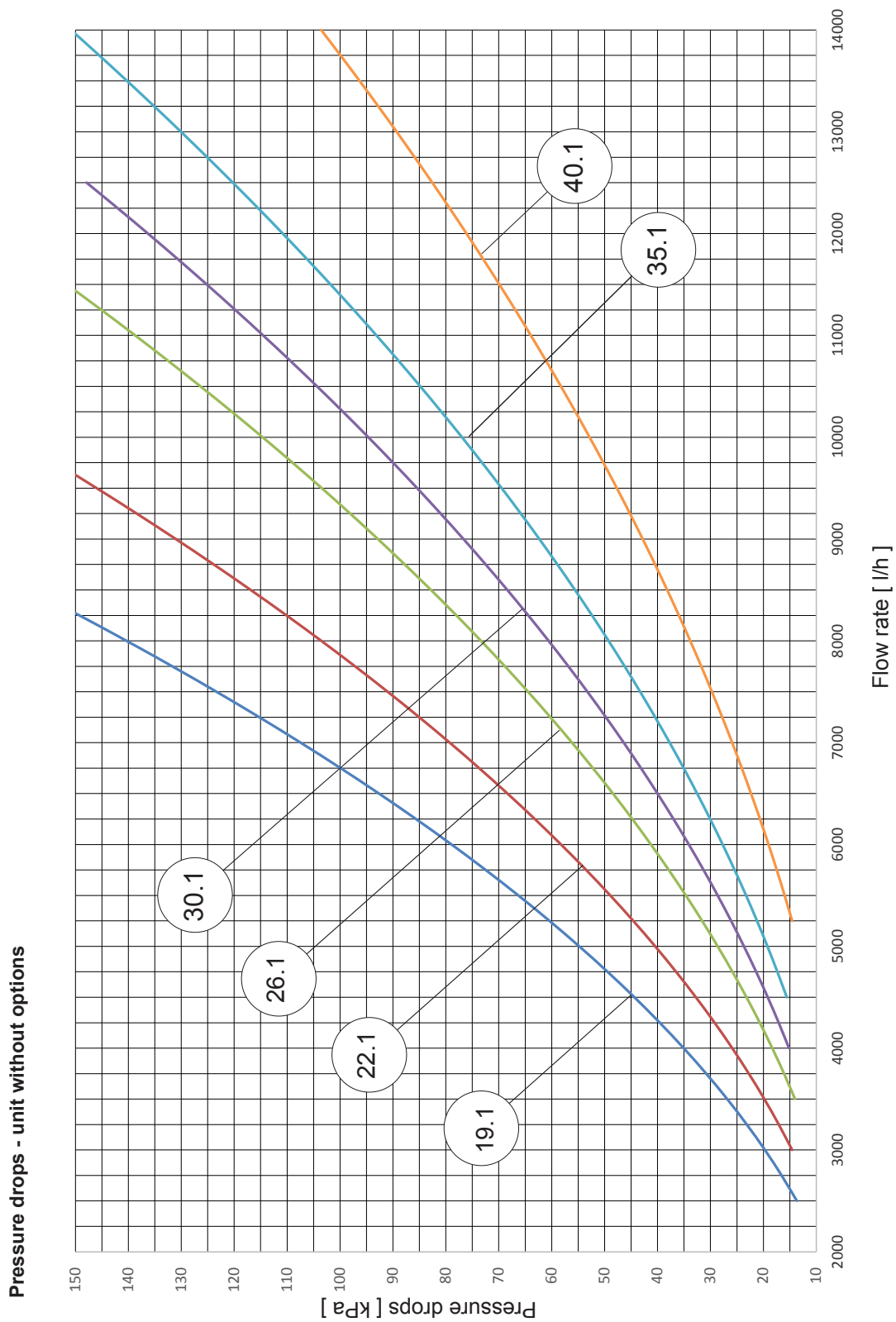

MODELS		19.1	22.1	26.1	30.1	35.1	40.1	UM	NOTE
Lower limit value	Q	2500	3000	3500	4000	4500	5250	l/h	Q= Water flow rate
Upper limit value	Q	8500	10000	11500	12500	140000	14000	l/h	

The graphs are referred to units operating with water at the temperature of 10°C (density 1000 kg/m³).

# WORKING HEAD

Available static head - unit with option "Storing and pumping module" :  
 "Standard pump" or "Tank and standard pump"  
 "Modulating pump" or "Tank and modulating pump"

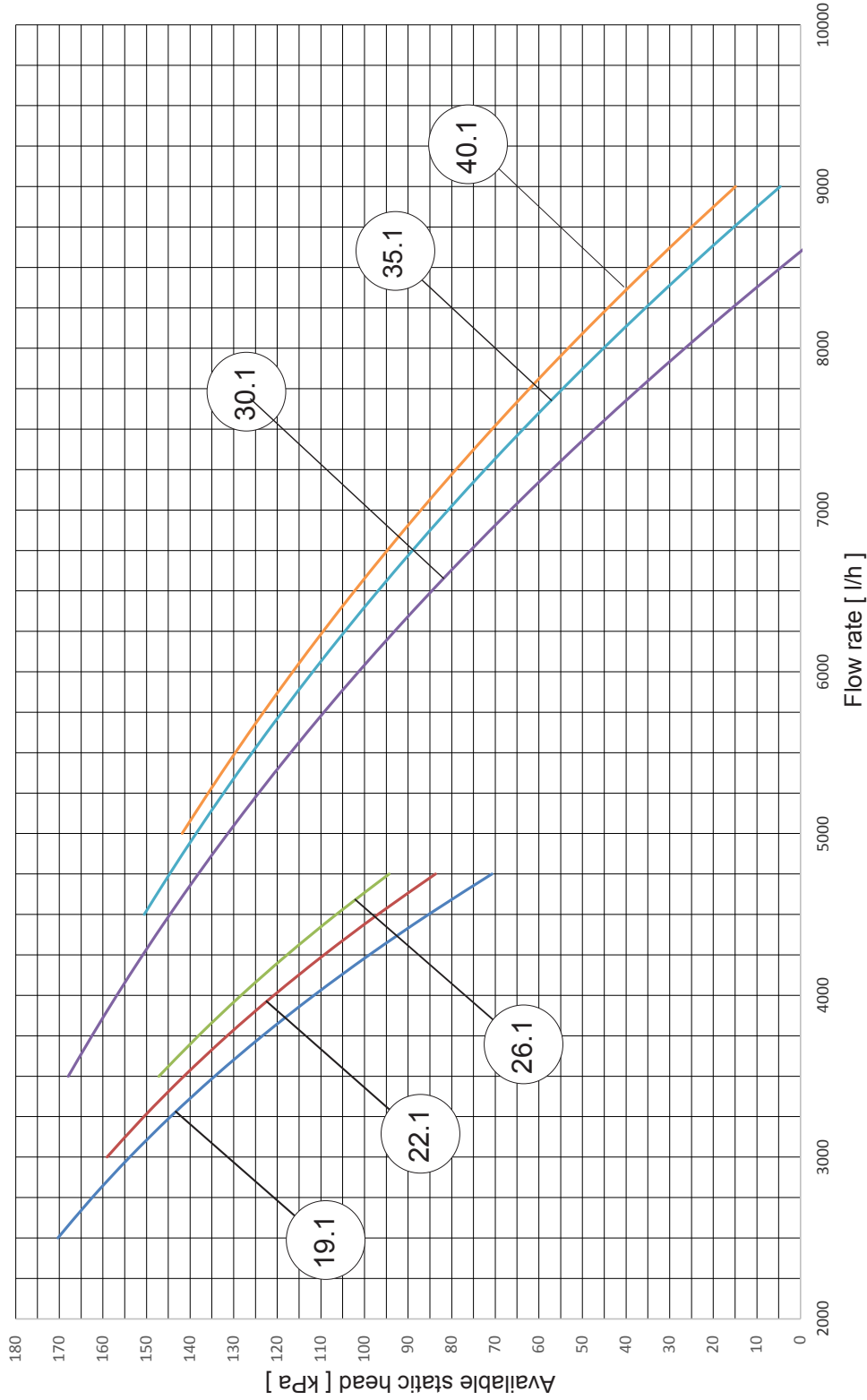

MODELS		19.1	22.1	26.1	30.1	35.1	40.1	UM	NOTE
Lower limit value	Q	2500	3000	3500	4000	4500	5250	l/h	Q= Water flow rate
Upper limit value	Q		4750		7800	8500	8900	kPa	

The graphs are referred to units operating with water at the temperature of 10°C (density 1000 kg/m³).

# WORKING HEAD

Available static head - unit with option "Storing and pumping module":  
 "High head pump" or "Tank and high head pump"

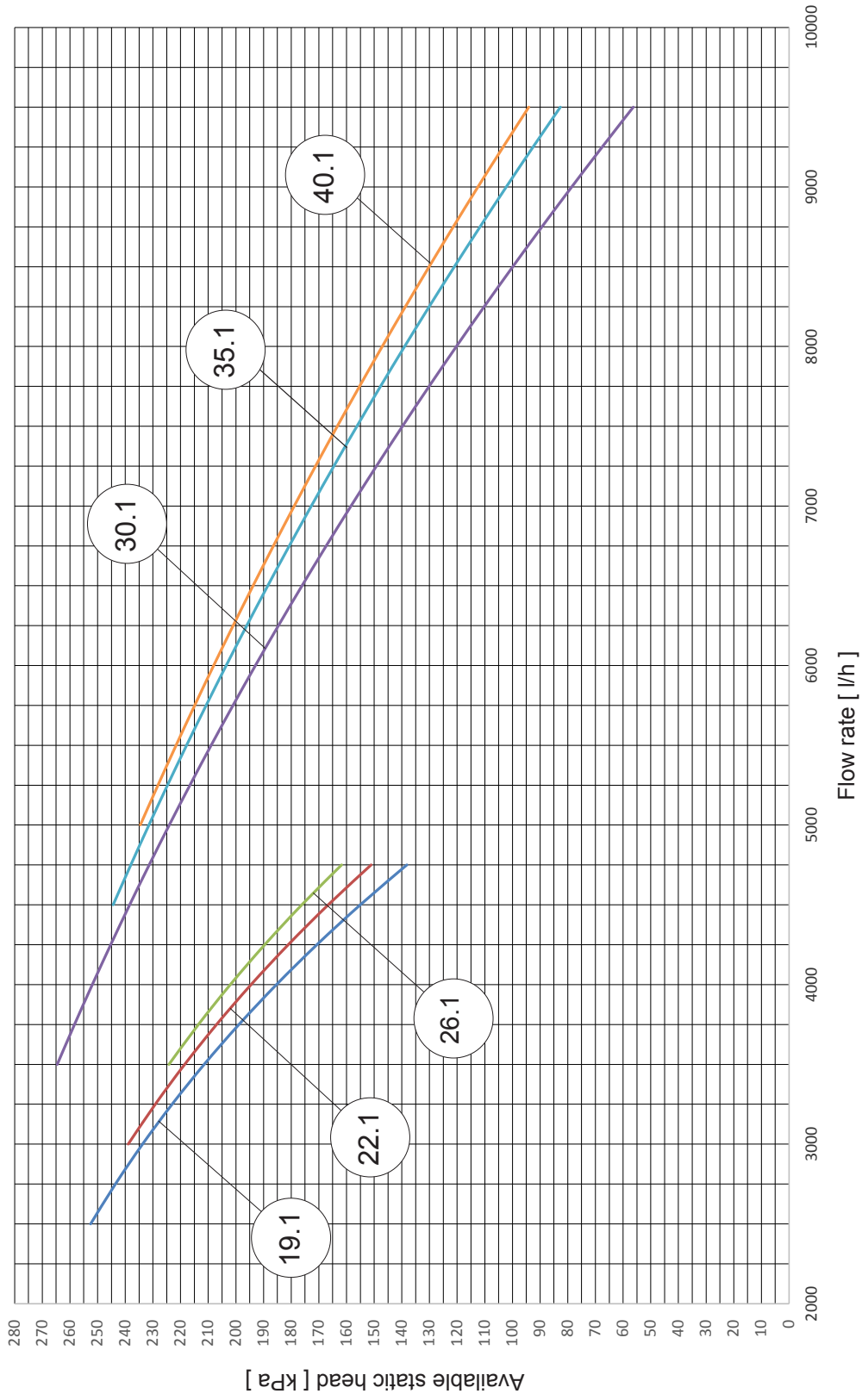

MODELS	19.1	22.1	26.1	30.1	35.1	40.1	UM	NOTE
	Q	Q	Q	Q	Q	Q	Q	
Lower limit value	2500	3000	3500	4000	4500	5250	l/h	Q= Water flow rate
Upper limit value	Q	Q	Q	Q	Q	Q	kPa	

The graphs are referred to units operating with water at the temperature of 10°C (density 1000 kg/m³).

# WORKING HEAD

## Source side aeraulic performances

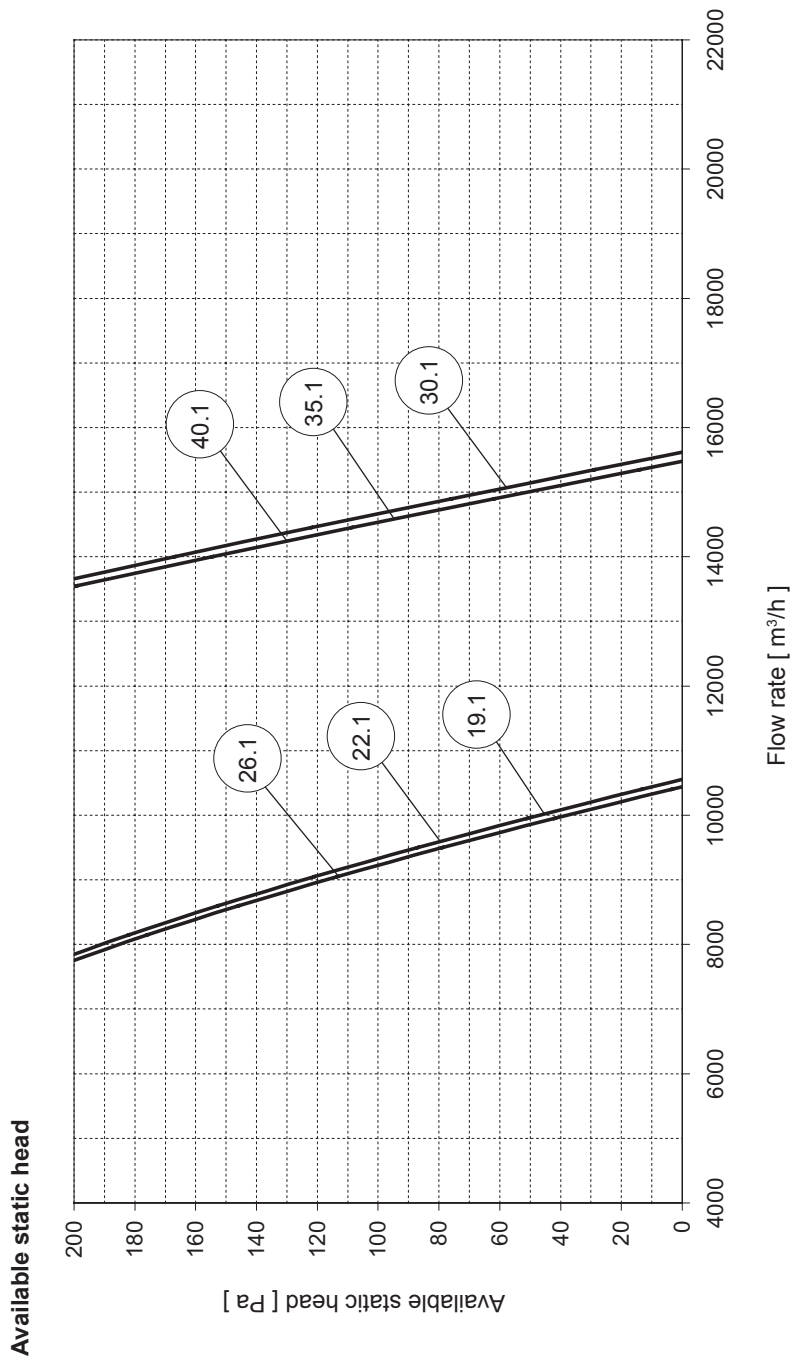

Frame	1			2		
	Model	19.1	22.1	26.1	30.1	35.1

Maximum available static head	200	200	200	200	200	200	Pa
-------------------------------	-----	-----	-----	-----	-----	-----	----

In case of ducted installation the total pressure drops in the inlet and outlet ducts can not exceed the maximum available static head. The minimum duct section must guarantee that the medium air velocity does not exceed 2.5 m/s in order to avoid noise problems and to keep the pressure drops lower as possible.

The graphs are referred to units operating with air at the temperature of 15°C (density 1,2 kg/m³).

## DIMENSIONAL AND PHYSICAL DATA

### Overall dimensions

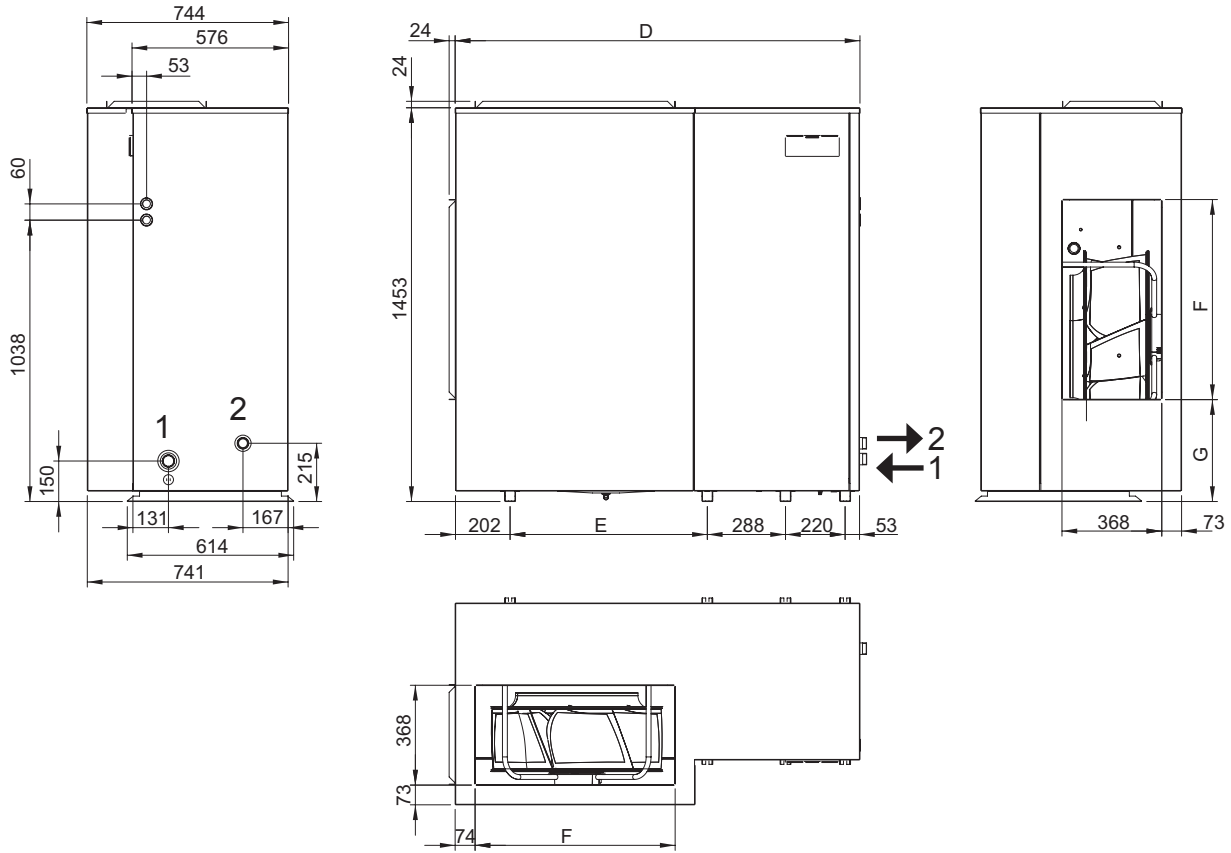

	Frame	1			2			
		Model	19.1	22.1	26.1	30.1	35.1	
IN water	1	1"1/4 F	1"1/4 F	1"1/4 F	1"1/4 F	1"1/4 F	1"1/4 F	-
OUT water	2	1"1/4 M	1"1/4 M	1"1/4 M	1"1/4 M	1"1/4 M	1"1/4 M	-
	D	1494			1704			mm
	E	728			938			mm
	F	738			948			mm
	G	376			271			mm

### Minimum operating area

Respect the free area around the unit as shown in the figure in order to guarantee a good accessibility and facilitate maintenance and control operations.

A	400 mm
B	450 mm
C	200 mm

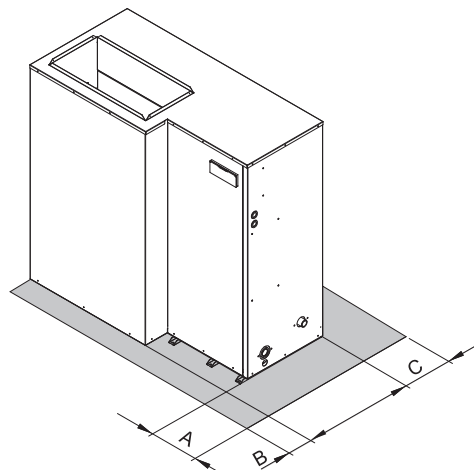

The manufacturer declines all responsibility for any inaccuracies in this manual due to printing or typing errors.  
The reserves the right to modify the products contents in this catalogue without previous notice.

## DIMENSIONAL AND PHYSICAL DATA

### Weights

Frame	1			2			
Model	19.1	22.1	26.1	30.1	35.1	40.1	U.M.

#### Empty weight

Unit without options			270	273	296	301	324	326	kg
Options	Storing and pumping module	Standard pump	9	9	9	9	11	11	kg
		High head pump	12	12	12	12	13	13	kg
		Modulating pump	12	12	12	14	16	16	kg
		Tank and standard pump	31	31	31	31	33	33	kg
		Tank and high head pump	34	34	34	34	35	35	kg
		Tank and modulating pump	34	34	34	36	38	38	kg
	Integrative electrical heaters	Standard in the tank	5	5	5	5	5	5	kg

#### Transport weights

Unità senza opzioni			286	289	312	321	344	346	kg
Options	Storing and pumping module	Standard pump	9	9	9	9	11	11	kg
		High head pump	12	12	12	12	13	13	kg
		Modulating pump	12	12	12	14	16	16	kg
		Tank and standard pump	31	31	31	31	33	33	kg
		Tank and high head pump	34	34	34	34	35	35	kg
		Tank and modulating pump	34	34	34	36	38	38	kg
	Integrative electrical heaters	Standard in the tank	5	5	5	5	5	5	kg

#### Operating weights

Unità senza opzioni			274	277	301	306	330	332	kg
Options	Storing and pumping module	Standard pump	10	10	10	10	12	12	kg
		High head pump	13	13	13	13	14	14	kg
		Modulating pump	13	13	13	15	17	17	kg
		Tank and standard pump	117	117	117	117	119	119	kg
		Tank and high head pump	120	120	120	120	121	121	kg
		Tank and modulating pump	120	120	120	122	124	124	kg
	Integrative electrical heaters	Standard in the tank	5	5	5	5	5	5	kg







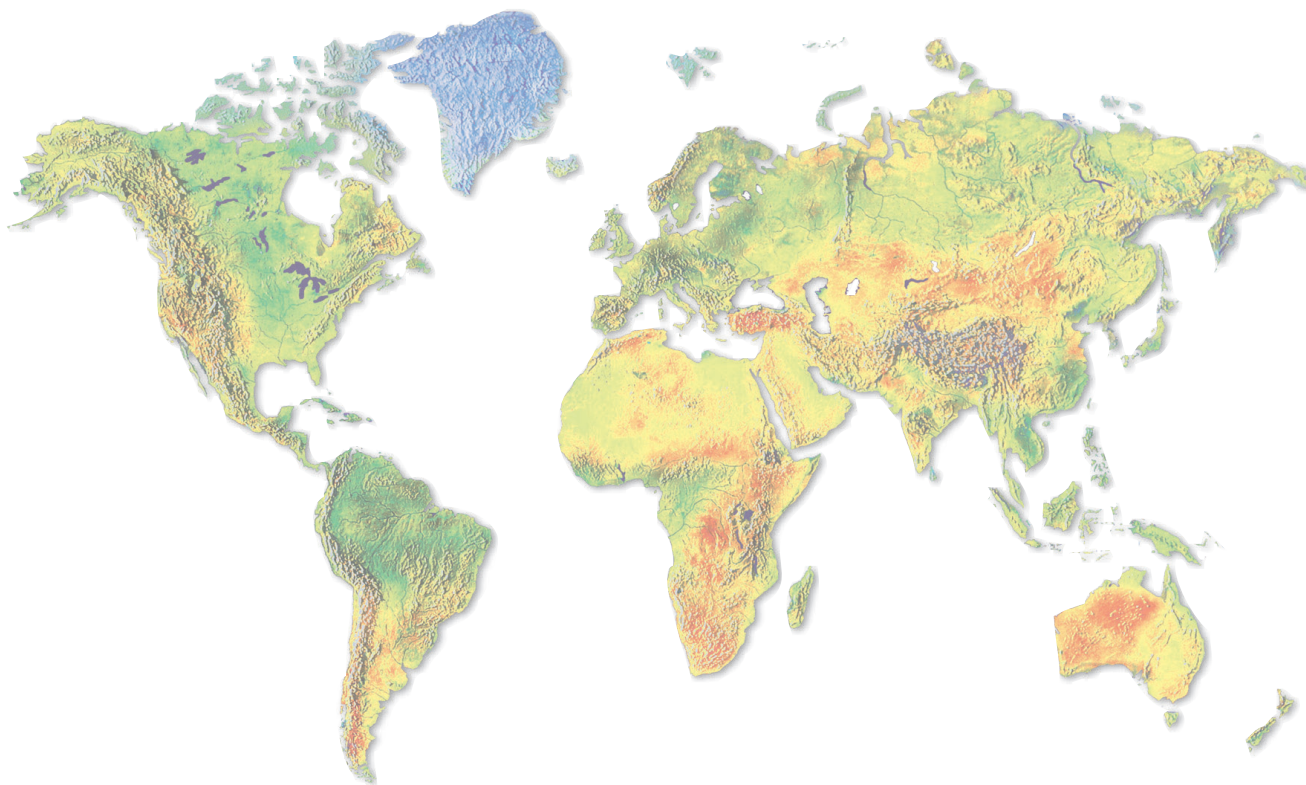

## **FERROLI** *around the World*

**ITALY** [www.ferroli.it](http://www.ferroli.it)

**SPAIN** [www.ferroli.es](http://www.ferroli.es)

**FRANCE** [www.ferroli.fr](http://www.ferroli.fr)

**GERMANY** [www.ferroli.de](http://www.ferroli.de)

**UNITED KINGDOM** [www.dpac.co.uk](http://www.dpac.co.uk)

**NETHERLANDS** [www.ferroli.nl](http://www.ferroli.nl)

**CROATIA** [www.ferroli.hr](http://www.ferroli.hr)

**ROMANIA** [www.ferroli.ro](http://www.ferroli.ro)

**TURKEY** [www.ferroli.com.tr](http://www.ferroli.com.tr)

**HUNGARY** [www.ferroli.hu](http://www.ferroli.hu)

**POLAND** [www.ferroli.com.pl](http://www.ferroli.com.pl)

**UKRAINE** [www.ferroli.ua](http://www.ferroli.ua)

**RUSSIA** [www.ferroli-ac.ru](http://www.ferroli-ac.ru)

**BELARUS** [www.ferroli.klimatoff.com](http://www.ferroli.klimatoff.com)

**CHINA** [www.ferroli.com.cn](http://www.ferroli.com.cn)

### WARNING FOR TRADERS:

As part of its efforts to constantly improve its range of products, with the aim of increasing the level of Customer satisfaction, the Company stresses that the appearance, dimensions, technical data and accessories may be subject to variation. Consequently, ensure that the Customer is provided with updated documents. The products described in this document are covered by warranty if purchased and installed in Italy.

